

ASM090-E



Parking areas, entrances, walkways, underpasses,
loading docks, recreation areas, tunnel.

GENERAL SPECIFICATION

- UL listed for wet location and concrete and wood mounting.
- Three pieces precise heavy duty die casting aluminum powder coating finished.
- Heat and impact resistant tempered glass lens.
- Heavy duty silicone rubber gasket included.
- Precise designed reflector for the best light efficiency.
- Dual-direction J-box design for horizontal and vertical mounting.
- Complete Stainless Steel external hardware.

DIMENSIONS

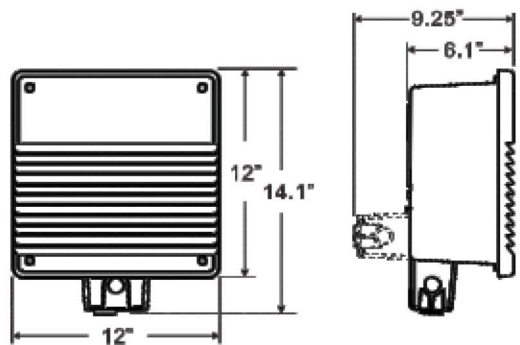

LINE DRAWING

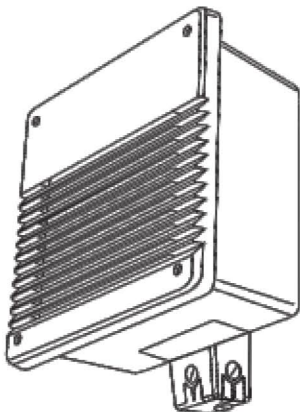

PHOTOCONTROL



ITEM NO.	LAMP	VOLTS	BALLAST
SM090E-P242	2X42W/CFL		HX-HPF
SM090E-S10	HPS100W/ED17/E-26	QUAD	HX-HPF
SM090E-H10	MH100W/ED17/E-26	QUAD	HX-HPF