

ASM-23 CEILING MOUNT

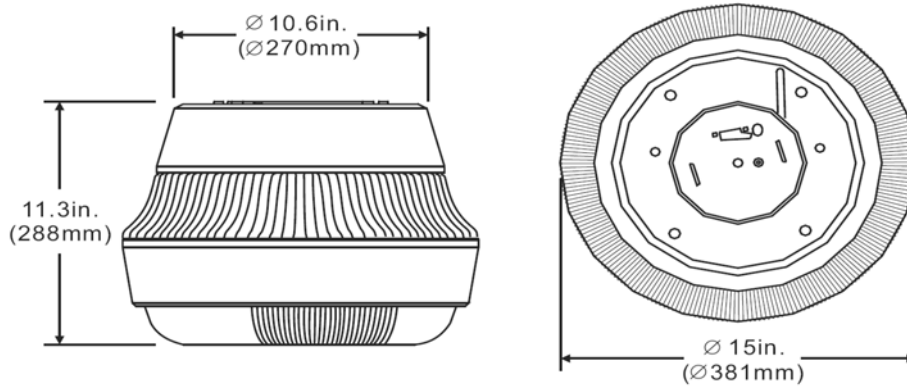

PRODUCT FEATURES



IDEAL FOR PARKING AREAS,
ENTRANCES, WALKWAYS,
UNDERPASSES, LOADING DOCKS,
RECREATION AREAS.

- * UL LISTED FOR WET LOCATIONS
- * HEAVY DUTY DIE-CAST ALUMINUM HOUSING WITH HIGH IMPACT UV ACRYLIC LENS
- * FOR COVERED CEILING MOUNT ONLY
- * WHITE COLOR
- * POWDER COATED FINISH ON THE HOUSING
- * HIGH IMPACT UV ACRYLIC LENS
- * ONE PIECE ANODIZED ALUMINUM DESIGNED REFLECTOR FOR BEST LIGHT EFFICIENCY
- * IDEAL FOR MH 175 WATTS, HPS 150 WATTS MAX AND 2 PL 42W

CATALOG #	RATING	LAMPS	DIMENSIONS
ASM23-MH	175W MAX MT (SPECIFY WATTAGE)	METAL HALIDE	Ø 15" X 11.3"D
ASM23-HPS	150W MAX MT (SPECIFY WATTAGE)	H.P.S	Ø 15" X 11.3"D
ASM23-2PL42	84W MAX 120-277 (SPECIFY WATTAGE)	2-PL42	Ø 15" X 11.3"D

